

Vehicle CO Gas Alarm



Introduction

This CO gas alarm can detect CO gas inside the vehicle. If the CO gas inside the vehicle is higher than the alarm value, it will alarm you by both sound and light. To avoid health damage and be your best assistant for human body ---Vehicle CO Gas Alarm.

01

Overview

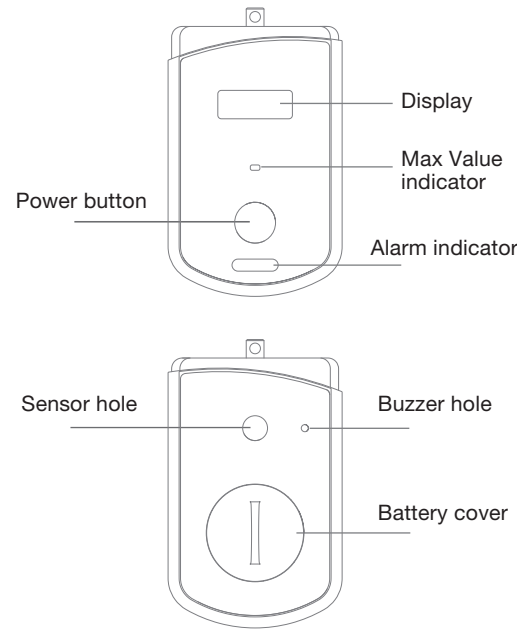

02

Packing list

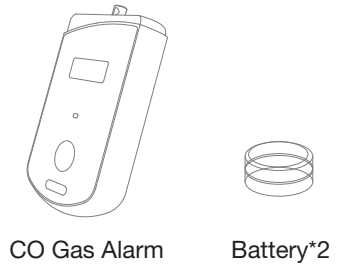

CO Gas Alarm

Battery*2

Recommended Placement

Hanging around vehicle Rear-view mirror or any place where does not block driver's sight.

⚠ Attention !

Do not place any objects close to the back of CO alarm, in case it affects its function and buzzer sound.

03

Specification

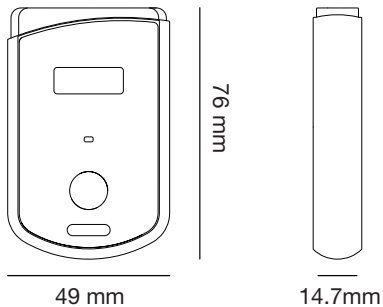

Size : 76*49*14.7mm

Weight : 45g (without battery), 50.8g (with battery), Clip:30.2g

Sensor : electrochemical sensor from Nemoto, Made in Japan, 5 years' lifetime

Power source: 2*CR2032

Lifetime of batteries: continuously working for about 9 months

04

Display: display CO concentration and battery power

LED indicator: Blue power supply light and Red alarm light

Buzzer: sound alarm, 70dB at 1meter

Static working state current: < 30uA

alarm state current: < 6mA

working temperature: -10℃ - 60℃

working humidity: 10% - 90%RH

Notice

1. Do not change the program inside, or disassemble the alarm.
2. Do not place the alarm in drawers or corners.
3. Please change a new device, after 5 years' lifetime.

05

User's Instruction

Sound & Light indicator and Alarm

Display: Real-time show battery power and CO gas value.

Alarm

Once CO gas concentration is over standard, it will alarm by both sound and light. Alarm level depends on CO gas concentration in the air.

Alarm Level

CO concentration (ppm)	Alarm
0-199	No alarm: Real-time show gas concentration
200-299	Alarm Level I : show gas concentration; red light flashes after the time accumulates for 5 minutes.

06

300-399	Alarm Level II : show gas concentration; red light flashes; buzzer sounds "Du dudu" every second.
≥400	Alarm Level III : show gas concentration; red light flashes rapidly; buzzer sounds "Du dudu" continuously

High temperature alarm:

When temperature goes above 50℃, it will display "----" and won't work until the temperature drops.

Low battery alarm: once low battery, buzzer will sound "du du" to alarm you every 30 seconds.

07

Functions of Power button

1. Long press Power button for 3 seconds to activate or shut down this device. The warming up period will take 3 minutes with display showing "CAL"
2. Short press Power button, the MAX value will be showed from period of power-on to present time (record will be cleared when device is shut down)

08

Change the batteries

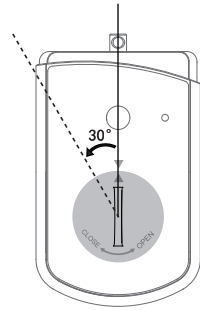

1. Use a coin (e.g. 1 dollar coin) to rotate 30°CCW, and then remove the battery cover.



3. When install new batteries, please make sure the battery cathode toward the outside.

2. Push clip following the direction of arrow, so the battery will pop up automatically.

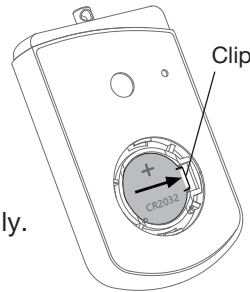

4. Rotate 30°CW to return it to the initial position.

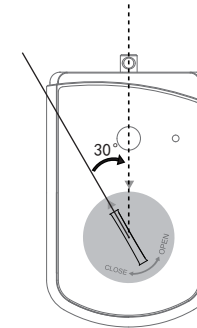

Attention !

To avoid scratches on the surface, please put a piece of cloth or tissue between the coin and the battery cover.

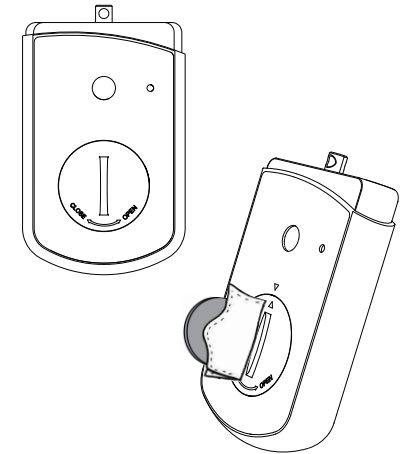

11

About CO (carbon monoxide)

CO inside the vehicle is mainly from the exhaust gas when the engine is running. When engine is raced in idling state, the burning is inefficient, the CO concentration will be increased; if the air conditioner is turned on when the car is parked and windows closed, air in the car can only convect through air conditioner, then CO gas generated by the engine will flow inside the car through air condition system, CO will accumulate more and more, human will be poisoned unconsciously. So it is very necessary to equip a carbon monoxide alarm in your car .

12

Concentrations of carbon monoxide and possible symptoms of healthy adults

Concentration of carbon monoxide in air	Approx. Inhaled time and symptoms may appear
24ppm (30mg/m ³)	Cause dizzy after 64 hours
50ppm (62.5mg/m ³)	Cause dizzy after 32 hours
100ppm (125mg/m ³)	Cause dizzy after 16 hours
200ppm (250mg/m ³)	After 2-3 hours, slight headache, fatigue, vertigo, nausea
400ppm (500mg/m ³)	In 1-2hours, headache; after 3hours, threaten life
800ppm (1000mg/m ³)	Cause vertigo, nausea, cramps within 45 minutes, lost consciousness within 2 hours, death within 2-3 hours

13

Attention: Above poisoning symptoms are meant for healthy adults, while for high risk and vulnerable people, or pregnant women, the consequence is quite different.

Kindly Reminder

1. Detection accuracy of the alarm is influenced by factors like device itself, temperature, humidity of install environment, etc. For installation, recommended proper temperature is 20℃ (±5℃); Relative humidity is 50%.
2. Keep the alarm away from electromagnetic interference which caused by cell phones or other electrical appliances.
3. Do not put the alarm in circumstances with relative humidity over 80%.
4. Keep the device away from corrosive or negative material and do not put it in high co concentration environment all the time, it will shorten its lifetime.

14